



Replacement procedure: Pre-CE TorqueMaster[®] (with counting wheel) by the "CE conform" TorqueMaster[®] Plus (with anti-drop system)

In order to bring the counterbalance system to the CE standard or in the case of broken spring(s) or damaged parts on an old TorqueMaster[®] system, please follow the instructions below to change the complete counterbalance system (springs, tube, drums, cables and support brackets).

WARNING : The TorqueMaster[®] counterbalance system comprises 1 or 2 springs, which can store great torque forces. Do not dismantle anything before you have ensured that the springs are completely unwound.

Necessary tools :

- 11mm forked spanner
- 11mm flat or angled spanner
- electric screwdriver (not hammer drill)
- 11mm hexagonal socket for electric screwdriver
- flat screwdriver
- flat pliers
- mallet
- bolt cutters (to cut cable surplus)
- ratchet
- 16mm socket for ratchet

NB: If the old TorqueMaster[®] has already been dismantled following spring breakage, go directly to step 4d.

Proceed with the door in closed position.

1) Checking the tension of the door counterbalance cables.

1a) taut cables: go to step 2, spring unwinding

1b) cables totally loose : go to step 3, unhooking the cables

2) Spring unwinding :

2a) Loosen slightly the locking screw, at the rear of the support bracket using an 11mm forked spanner and another 11mm spanner on the adjustment screw, on the front of the support bracket.

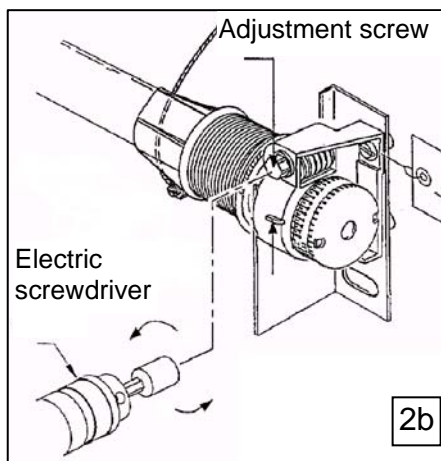
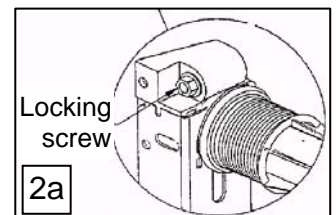

2b) Using an electric screwdriver (NOT a hammer drill) and an 11mm hexagonal socket, work on the adjustment screw of the RHS support bracket (seen from the inside of the garage), in UNSCREWING mode (anticlockwise) until the counting wheel is brought to "0".

- Proceed in the same way (always UNSCREWING) on the LHS support bracket if the TorqueMaster[®] has 2 springs.

- a complete absence of tension in the spring (for 1 spring doors, or both springs) should be visible when looking at the cables, which should be completely slack.

3) Unhooking the cables :

When the cables are TOTALLY slack, they can be unhooked from the bottom of the door.

The cable can be hooked up in several ways:

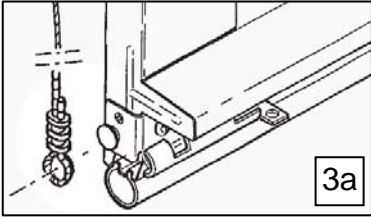

3a) TorqueMaster fitted to lintel (front-mounted) : the loop of the cable is hooked onto a lug, remove it by levering with a screwdriver.

3b) TorqueMaster fitted onto the end of the horizontal tracks (rear-mounted) : the loop is threaded onto a cotter pin and blocked by a clevis pin. Remove this from the cotter pin, then remove the cotter pin and the cable loop.

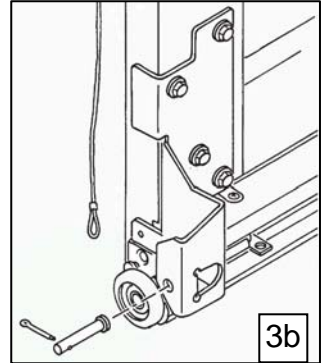

3c) Remove the cable taking care to check its path throughout its length : behind all of the guiding rollers on the panels (front counterbalance system), or on the sheave wheels (rear counterbalance system).

The following instructions explain dismantling / fitting of a FRONT TorqueMaster (lintel-mounted). For a REAR TorqueMaster, proceed in the same way, keeping the bolts of the 6x15 fixing screws for the support brackets.

4) Removal of the old counterbalance system :

- Begin on the RHS (seen from the inside of the garage).

4a) Remove the counting wheel, simply clipped onto the mechanism. It can only be removed in the position "0".

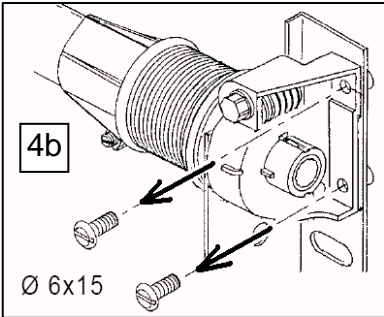

4b) Remove the 2 support bracket fixing screws (it may be necessary to remove the fixed gear to have access to the screws). Keep the screws.

Note: The screws can stand by the door frame. In this case, the wall bindings of the frame must be unscrewed, move away the frame from the wall and push the screws towards the wall to "unset" them from the

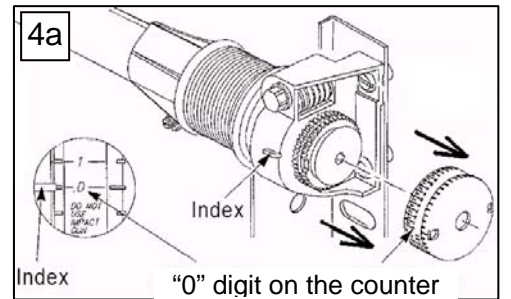

4c) Remove the support bracket by sliding it off sideways. Remove the large gear remaining on the fluted spring end. Repeat these operations for the LHS.

- Then lift up the TorqueMaster® tube, so that the spring ends come away from the RHS and LHS fixing brackets.

Note : On doors with integrated I-drive, unplug the mains supply cord, disconnect the release cable (hook), take off the bolts that fix the operator on the headroom, and take off the tube WITH the operator without removing it from the tube (risk of dislodging the ring inside the operator).

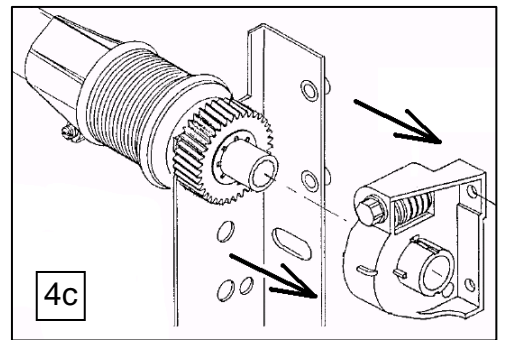

4d) Salvaging the old TorqueMaster® tube

If the spring(s) ONLY have been delivered (without the tube, owing to its length for example), it may be necessary to use the old tube.

Begin by removing the old drums from the tube and scrap them. On the other hand, it is ESSENTIAL not to damage the tube which must retain its special "water drop" shape. Thus, it is necessary to remove the old springs from the inside of the tube by sliding them off, eventually using piece of wood to remove them by tapping lightly. The spring should slide freely when the tube is tilted and come out easily.

At the end, the tube should be totally empty at both ends, it should not be dented nor have any mark which could prevent the new spring(s) sliding in it.

Note : Keep the operator on the tube when it is an I-drive integrated door (see 4c).

5) Assembly of the new TorqueMaster® Plus, with or without a new tube

5a) If the spring(s) ONLY have been delivered **without the tube** (owing to its length for example), begin by sliding each new spring into the tube :

Nozzles are screwed onto each end of the spring : a nozzle in the shape of the inside of the tube (inside nozzle) (3h) and the other nozzle, cylindrical ending in a hexagonal shape (outside nozzle). On this outside nozzle, is engraved LH or LEFT, or RH or RIGHT. Slide each spring, inside nozzle (3h) first, into the tube, the indications Left/Right on the outside nozzle correspond to the sense of fitting of the TorqueMaster, seen from the l'interior of the garage looking at the door. In the case of a TorqueMaster with ONLY ONE spring, it MUST be marked RH or RIGHT and be slipped into the RHS of the tube. The LHS will be equipped with a free nozzle, which will only be used as an axis of rotation.

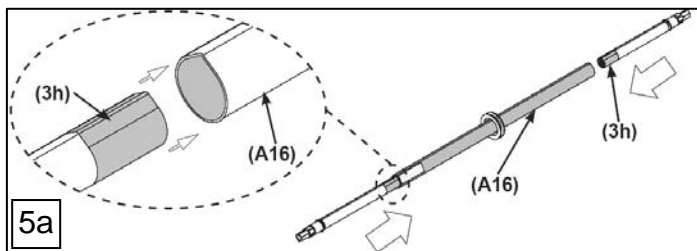

5b) If the new system has been delivered **with the tube**, place this tube on the ground, behind the door, the nozzle end marked RH or RIGHT on the RHS of the door (seen from the inside of the garage)

5c) Slot the new cable drums (with the moulded cogged wheel) onto the tube respecting the LETTERS ENGRAVED on each drum: RH or RIGHT goes on the RHS, and LH or LEFT goes on the LHS of the tube. In the case of a TorqueMaster with only one spring, slide the free nozzle (A31) onto the LEFT drum, with the hexagonal shape towards the outside of the drum, BEFORE slotting the drum onto the tube. The drum has the same inside shape as the tube and can only be mounted in one way. Push each drum well onto the tube using a rubber mallet if necessary.

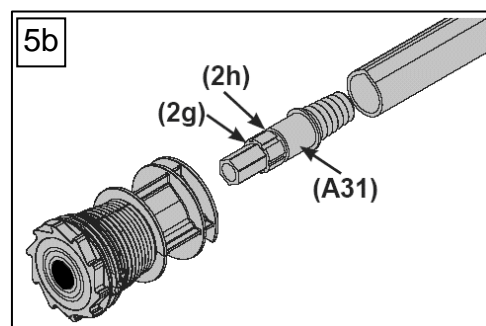

6) Mounting the tube and drums on the old support brackets:

Lift up the tube + drum assembly, taking care to keep each spring end outside the drum. The end of the spring has a groove (2h) in the cylindrical part (2g). This groove should be located flush with the drum and should slot into the curved notches on the fixing brackets (A5).

Note : On door with I-drive operator, put back the operator's fixing screws removed at point 4c and connect again the manual release cable.

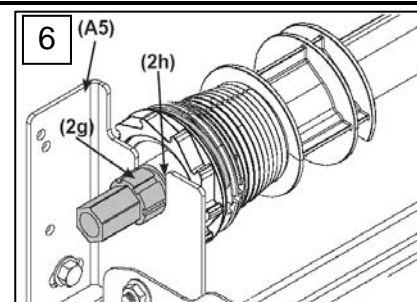

7) Fitting the anti-drop assemblies :

The anti-drop mechanism is constituted of the pawl (claw), situated in the end bracket and the toothed wheel (2t) which will be interdependent with the spring.

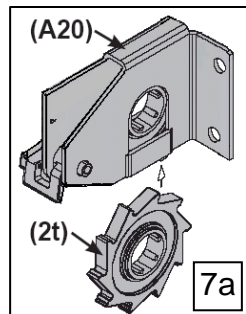

7a) ONE-spring TorqueMaster:

Slide the toothed wheel (2t) into the RHS anti-drop bracket (A20).

The LHS end bracket does not have a toothed wheel (no LH spring in the tube), nor pawl.

7b) TWO-spring TorqueMaster:

Slide the toothed wheels into the two anti-drop brackets (same sense as the teeth on the drum).

7c) Slide each end bracket with its toothed wheel onto the spring end (RHS and LHS if 2 springs ; the LHS bracket without toothed wheel if only 1 spring). The exterior part of the pawl should slot onto the toothed part of the drum.

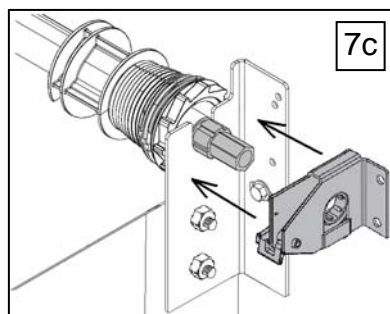

7d) Fix the end bracket onto the fixing bracket using the 2 screw $\varnothing 6 \times 15$ removed in step 4b (and the bolts, in rear mounting).

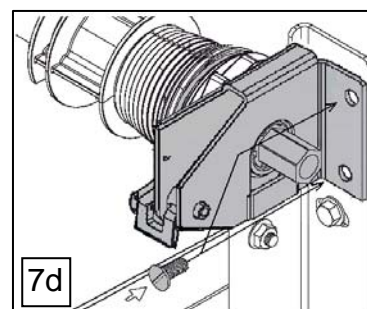

8) Hooking-up the cables.

Pass the cables along the same path as when dismantling, step 3c :

8a) In front-mounted TorqueMaster, pass the cable loop behind all the rollers guiding the sections and hook it up on the lug at the bottom of the door. Lever with a screwdriver to hook on the loop.

8b) In rear TorqueMaster, pass each cable over the sheave wheel, then hook it onto the bottom bracket of the door with the cotter and clevis pins, dismantled in step 3b.

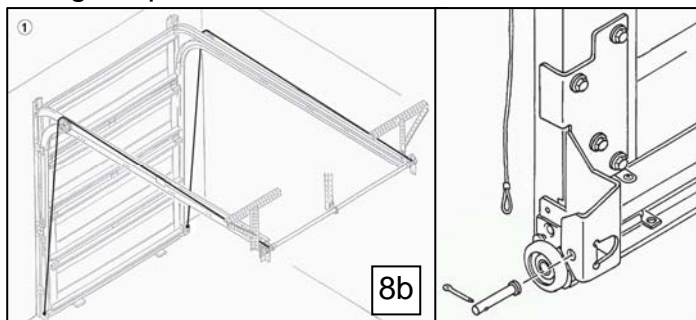

9) Adjustment of cable length.

NB : Check that the panel set is level on the ground.

Turn the TorqueMaster tube in such a way as to bring the cable locking screw (2n) to face you. Loosen this screw one turn maximum. Pull through the cable end (2o) using pliers until all of the slack in the cable is removed. Check that the cable is correctly positioned in the first groove (2p) of the drum. Tighten the screw (2n) until it bites, then tighten one-and-a-half extra turns (1.5 turns).

Proceed in the same way for both sides.

To check that the two cables are the same length, turn the tube to wind the cables : both sides should tighten at the same time.

The cable surplus coming out of the tube can be cut (using bolt cutters), leaving a few cm, or attached to the tube using collars or adhesive tape.

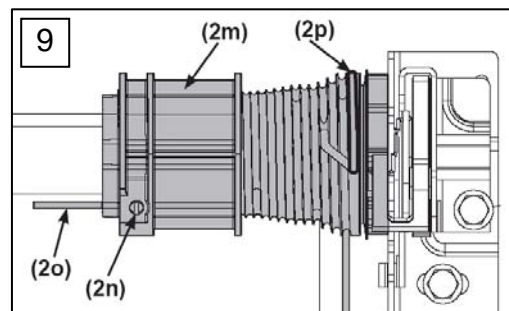

10) Tensioning the spring(s).

- Begin by the RHS

- Put the ratchet into "adjustment" position (2q).

- Using a ratchet (B6) and a 16mm socket (B14), tighten the spring 14 turns, pulling the ratchet downwards towards the back of the garage.

- For a TorqueMaster with only one spring, go to step 11 ; for a TorqueMaster with two springs, proceed in the same way as above for the left hand side. On the left, tighten the spring 14 turns in the same way.

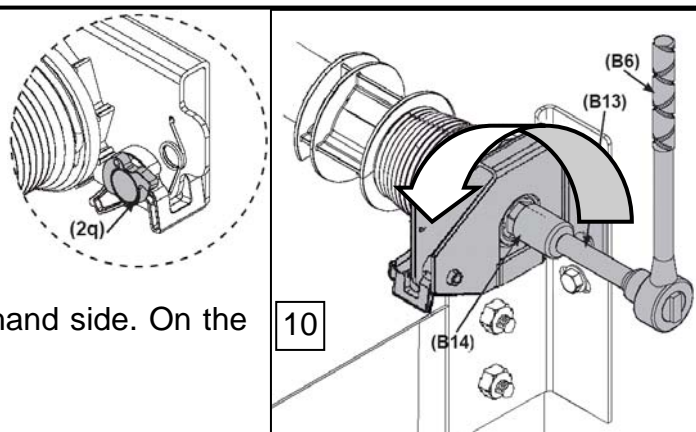

11) Checking the door counterbalancing.

14 turns of tension of the spring(s) is the average value for a door 2m high. It is necessary to adjust the tension according to the door dimensions.

- The door handling should be as easy going up as going down.

- If the door drops, it is necessary to further tighten the spring(s). Repeat from step 10, proceeding by 1/2 extra turns. The maximum tension of 18 turns corresponds to a door 2.44m high. Add the same tension on the RHS as the LHS for a 2-spring TorqueMaster.

- If the door goes up on its own, the spring(s) are too tight. Proceed as for step 10 in order to tension the springs, but place the ratchet horizontally and press down on it. Whilst pressing on the ratchet, press on the claw of the anti-drop system and let the ratchet come up slowly to move onto the next tooth of the wheel, under spring tension. Proceed tooth by tooth until the correct tension is obtained (on the RHS and the LHS for 2 springs).

12) Putting the anti-drop system into operational mode.

When the counterbalancing is correct, put the claw in position (2s), position "Utilisation" (the shape of the claw lines up with the form of the pawl).

The anti-drop function will only be ensured if the claw is in this "Utilisation" position.

Note : On doors with i-drive operator, it is necessary to make the automatic installation procedure of the operator again (see the door fitting instructions).

